

THANK YOU...

Thank you for purchasing the P.T.Rail™. We are confident that you will find the unique design and durable construction of this product to be of great assistance in your daily routine.

To fully enjoy your P.T.Rail™, please take a few moments to read these instructions. You should store these instructions in a safe place for future reference.

SAFETY CONSIDERATIONS

CAUTION: It is your responsibility to see that your P.T.Rail™ is properly assembled, installed, and cared for. Failure to follow instructions in this manual could result in serious injury. Support rails can be slippery when wet - use this product with caution.

P.T.RAIL™ INSTALLATION

The P.T.Rail™ should only be installed in areas where the mounting surface is structurally sound. Strengthening modifications may be required. If you are not equipped to undertake the outlined work we recommend that you have your P.T.Rail™ installed by a qualified contractor. Suggested maximum user weight 400lbs/181kg, however this rating is conditional upon suitable fasteners and supporting surface.

WARRANTY

All HealthCraft™ Products are covered by a one year limited warranty with the exception of hand grips which are subject to normal wear. Buyer hereby indemnifies, agrees to hold harmless and defend HealthCraft™ Products Inc. from and against any and all liabilities, claims, (founded and unfounded), losses, damages, costs and expenses (including without limitation consequential damages and reasonable professional fees) resulting from buyers specification, application, or improper use of goods described hereon; buyers omission or neglect.

HealthCraft™ Products Inc. does not assume any liability for damage resulting from services performed by others or faulty installation, misuse or misapplication of goods sold by HealthCraft™ Products Inc.

HealthCraft™ Products Inc. shall not be liable for prospective profits or special, indirect, or consequential damages, or for the cost of any corrective work done without HealthCraft™ Products Inc. prior approval. HealthCraft™ Products Inc. total liability hereunder shall in no event exceed the purchase price of the goods specified hereon.

FASTENERS

The P.T.Rail™ must be secured with fasteners appropriate to the structural material of the wall. Each fastener must have a retention force rating of at least 330lbs/150kg (see **Figure 4** on page 2 for more information). Inspect, or have inspected (and tighten if necessary) the screws on a monthly basis.

MOUNTING LOCATIONS

We strongly recommend that you give some thought as to the optimal location of your P.T.Rail™ before installation. The following suggestions are offered for your consideration, however, it is recommended to consider advice from the appropriate healthcare professional regarding the placement of any support rail.

- The P.T.Rail™ typically provides the optimal support with a height to top rail (H) of between 32-34" (81-86 cm), or more in some cases.
- The P.T.Rail™ may be installed on one or both sides of a toilet. In the case of one P.T.Rail™ being installed on both sides of the toilet, a suggested width between top rails (W) would be in the range of 28-32" (71-81cm).
- Ensure the location of the P.T.Rail™ will not obstruct access to other parts of the bathroom. For hinged models, ensure that the space above the rail is adequate to permit folding.

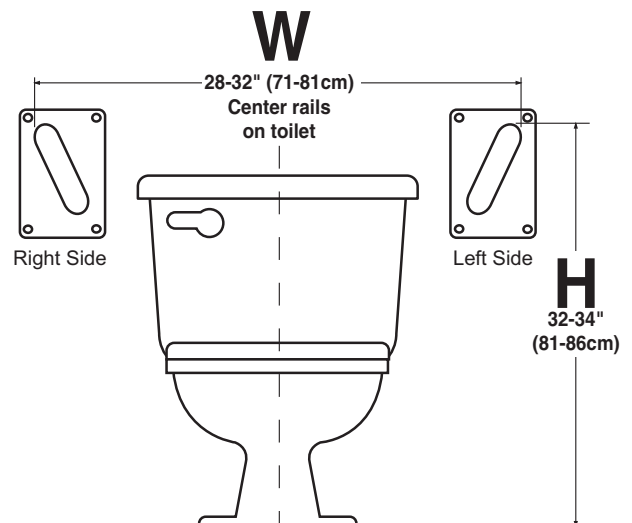

P.T.RAIL MODELS

P.T.Rail Hinged Right Side
PT-WR28R
PT-WR32R

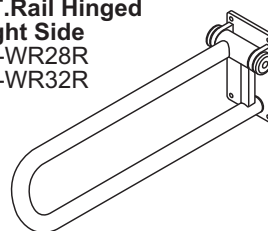

P.T.Rail Fixed Right Side
PT-FIX28R
PT-FIX32R

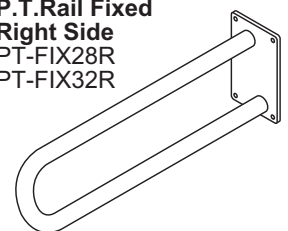

P.T.Rail Hinged Left Side
PT-WR28L
PT-WR32L

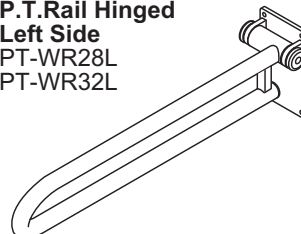

P.T.Rail Fixed Left Side
PT-FIX28L
PT-FIX32L

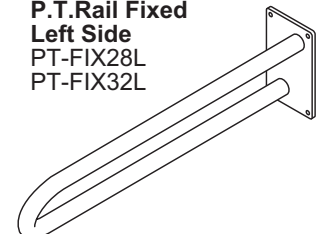

P.T.RAIL™ INSTALLATION INSTRUCTIONS

NOTE: Due to variances in local construction methods and materials used, details given below are suggestions only. Consult the appropriate local contractor for specific advice. For concrete walls, you may be able to install fasteners (such as a wedge anchor) directly into the concrete wall without modification. If unable to cut open walls to add reinforcement, see "Alternative to Cutting Open Walls" below.

1. Choose optimal mounting location of rail including height (H) and side to side location (L) as shown in **Figure 1a**. Record the height and location on the wall for use in step 7.
2. Find wall support studs & cut hole in wall board to expose wall studs as shown in **Figure 1b**. Expose half width of each stud to facilitate re-installation of wall board patch. Suggested hole size is height (A) of 18-24" (48-61cm) and width (B) corresponding to wall stud spacing. **NOTE: Take care for any utilities located in wall!**
3. Fabricate a support frame structure from suitable wood pieces as shown in option **Figure 2a (2"x4" Frame Construction)** or **2b (Plywood Sheet Construction)**. Use a generous quantity of wood screws and glue to hold the support frame structure together as shown. Support frame width (D) should fit snugly between wall studs. Support frame height (E) should be from 24-32" (61-81cm) high or more, depending on material and stiffness of wall studs. For support frame structure in **Figure 2a**, locate top cross member (F) to position in line with top fastener holes when rail is located at the height (H). Lower cross members (G) should be spaced 8" (20cm) from top cross member.
4. Insert support frame structure through hole in wall as shown in **Figure 3a**. When the frame is at the correct height, secure uprights to wall studs using a generous amount of wood screws.
5. Hold the P.T.Rail™ against the support frame to confirm the cross members are in the correct location as shown in **Figure 3b**.
6. Patch cutout to match the surrounding wall as shown in **Figure 3c**.
7. Install P.T.Rail™ in the location recorded in step 1. Secure with four fasteners as shown in **Figure 4**. See below for fastener recommendations.

USER WEIGHT	FASTENER	FASTENER RATING
200 lbs/90kg	*1/4" dia wood lag	330lbs/150kg
350 lbs/160kg	*5/16" dia wood lag	580lbs/263kg

(*Suggestion only based on min 2.5"/6.3cm thread engagement in quality wood in pre-drilled pilot hole)

Your P.T.Rail™ installation is now complete.

ALTERNATIVE TO CUTTING OPEN WALLS...

If unable to cut open walls to add reinforcement, consider a P.T.Rail™ Plywood Wall Plate (sold separately). This plywood plate secures to wall studs through the wall board. Can be painted to match wall colour. P.T.Rail™ mounting hardware included.

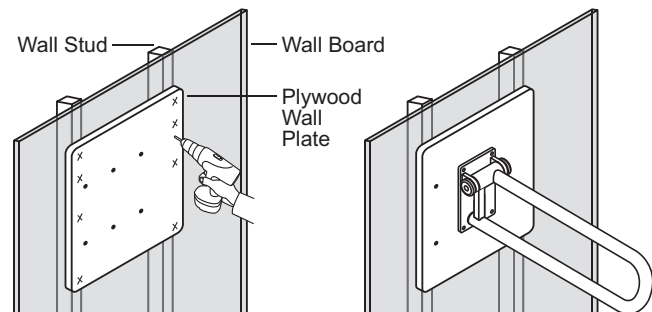

Figure 1.

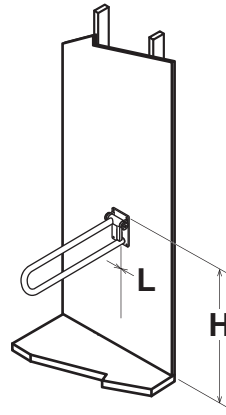

Figure 1b.

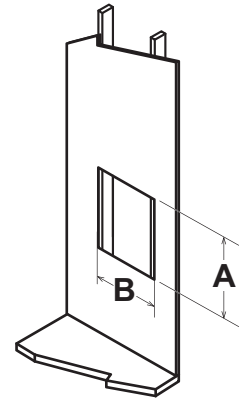

Figure 2a.
2"x4" Frame Construction.

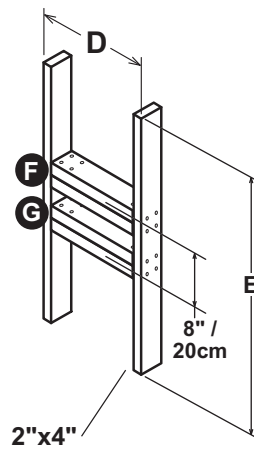

Figure 2b.
Plywood Sheet Construction.

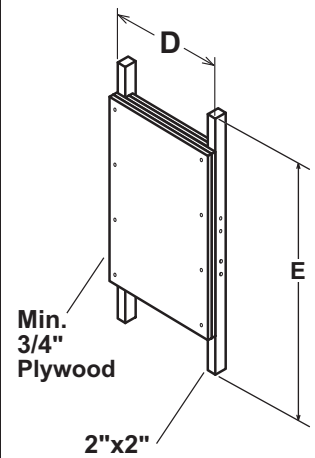

Figure 3.

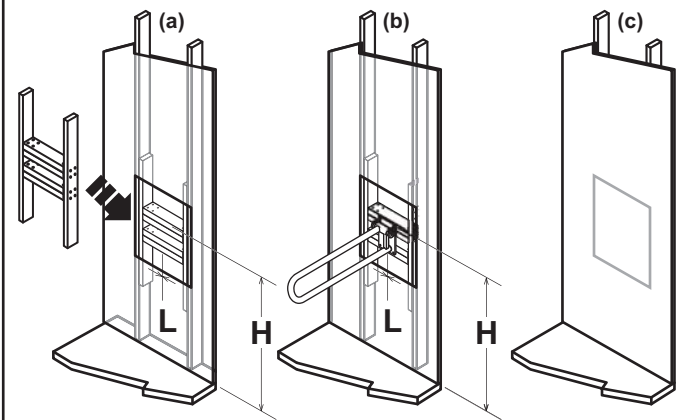

Figure 4.

